

After Sales Technical Documentation NHE-6 and NHK-6 Series Transceivers

Chapter 5

UIF MODULE GU8

CHAPTER 5 – UIF MODULE GU8

Contents

Introduction	Page 5-3
External Signal and Connections	Page 5-3
UIF Module Main Connector, X400	Page 5-3
LCD Display Module Connector X401	Page 5-4
Technical Outline	Page 5-5
Mechanics	Page 5-5
Electronics	Page 5-6
Functional Description	Page 5-6
Circuit Description	Page 5-6
Circuit Diagram of GU8	Page 5-9
Layout Diagram of GU8	Page 5-10
Parts List of GU8 (EDMS issue: 1.9)	Page 5-11

Introduction

This document describes the UIF module GU8. GU8 is used in both GSM (NHE-6) and PCN (NHK-6) transceivers.

External Signal and Connections

There are two connectors in this module: X401 (the Display Module Connector) and X400 (UIF Connector)

UIF Module Main Connector, X400

Pin/Conn	Line Symbol	Notes
1/X400	MICP	Positive Mic terminal • min/typ/max : 0...2...12.5 mVAC
2/X400	MICN	Negative Mic terminal • min/typ/max : 0...2...12.5 mVAC
3,6,30/X400	GND	Digital ground
4/X400	VL	Logic voltage • min/typ/max : 3.0...3.16...3.3 V
5/X400	SYSRESET X	Reset for display driver
7/X400	KEYLIGHT	Keymat backlights OFF • min/typ/max : 0...0...0.2 V Keymat backlights ON • min/typ/max : 2.8...3.16...3.3 V
8/X400	LCDLIGHT	LCD backlights OFF • min/typ/max : 0...0...0.2 V LCD backlights ON • min/typ/max : 2.8...3.16...3.3 V
9/X400	BUZZER	Ground
10/X400	GND	
11/X400	SLIDEON	Slide pos. sensing • min/max : 0...3.3 V
12/X400	GENSCLK	Display data clk LOW • min/typ/max : 0...0...0.6 V Display data clk HIGH • min/typ/max : 2.4...3.16...3.3 V

Pin/Conn	Line Symbol	Notes
13/X400	GENSD	Display data line LOW • min/typ/max : 0...0...0.6 V Display data line HIGH • min/typ/max : 2.4...3.16...3.3 V
14/X400	LCDENX	Display driver Enable • min/typ/max : 0...0...0.9 V Display driver Disable • min/typ/max : 2.4...3.16...3.3 V
15/X400	VB	Battery voltage • min/typ/max : 5.3...6.0...10.26 V
16/X400	XPWRON	Power key free, pull up in PSCLD • min/typ/max : 5.3...6.0...10.26 V Power key pressed • min/max : 0...0.4 V
17/X400	EARN	Negative Earpiece Terminal • min/typ/max : 0...14...220 mVAC
18/X400	EARP	Positive Earpiece Terminal • min/typ/max : 0...14...220 mVAC
19/X400	CALL_LED	Call indicator LED OFF • min/typ/max : 0...0...0.4 V Call indicator LED ON • min/typ/max : 2.4...3.16...3.3 V
20-25/X400	UIF(0:5)	LCD driving and keyboard ROW reading
26-29/X400	COL(0:3)	Column scan for key matrix

LCD Display Module Connector X401

Pin/Conn	Line symbol	Signal description
1/X401	V5	LCD driver supply voltage
2/X401	V4	LCD driver supply voltage
3/X401	V3	LCD driver supply voltage
4/X401	V2	LCD driver supply voltage
5/X401	V1	LCD driver supply voltage
6/X401	VDD	Supply voltage
7/X401	VR	Voltage adjustment pin
8/X401	VOUT	DC/DC voltage converter capacitor
9/X401	CAP2-	DC/DC voltage converter capacitor

Pin/Conn	Line symbol	Signal description
10/X401	CAP2+	DC/DC voltage converter capacitor
11/X401	CAP1-	DC/DC voltage converter capacitor
12/X401	CAP1+	DC/DC voltage converter capacitor
13/X401	GND	Ground
14/X401	OSC1	Feedback resistor of built-in osc.
15/X401	OSC2	Feedback resistor of built-in osc.
16/X401	GND	Ground
17/X401	A0	Control/display data flag input
18/X401	C86	μ P interface select input
19/X401	CS2	Chip select input
20/X401	CS1	Chip select input
21/X401	P/S	Parallel/serial data input select
22/X401	SI	Serial data input
23/X401	SCL	Serial clock input
24/X401	RES	Reset
25/X401	VDD	Supply voltage

Technical Outline

Mechanics

The modules are made from a single flexible printed circuit board – loaded with SMD components. A Flexible PCB was used for a number of reasons:

- The material is only 0.3mm thick – so the phone's height buildup can be kept to a minimum.
- The Volume and Power keys wiring can be folded to fit in the phone during assembly – since the circuit is flexible.
- Bending of UI-module

The major mechanical parts on the UIF assembly include the following:

- Display Module: LCD, LCD driver TAB circuit & Light-guide.
- Main Keydome assembly: Adhesive film holding 20 metal dome clickers
- Volume Keydome assembly: Adhesive film holding 2 metal dome clickers .
- Power Keydome assembly: Adhesive film holding 1 metal dome clicker
- Acoustic Components: Microphone and speaker connection to UI-board by using spring contacts

Electronics

The following sections of circuitry are included on the Flexi:

- Microphone Circuit
- Speaker Circuit
- Buzzer Circuit
- LCD Display Module
- LCD voltage divider circuit.
- Keyboard & Display lighting circuits
- Keyboard switch matrix.
- Power & Volume control switch matrix.
- Slide position sensing circuit.

Functional Description

Circuit Description

The module is connected with 30 pin connector (X400) to the system board.

The module includes following main functional blocks:

- Keyboard
- Illumination
 - microphone pads
 - earpiece pads
 - buzzer
- LCD interface
- Slide position sensing

Power Distribution

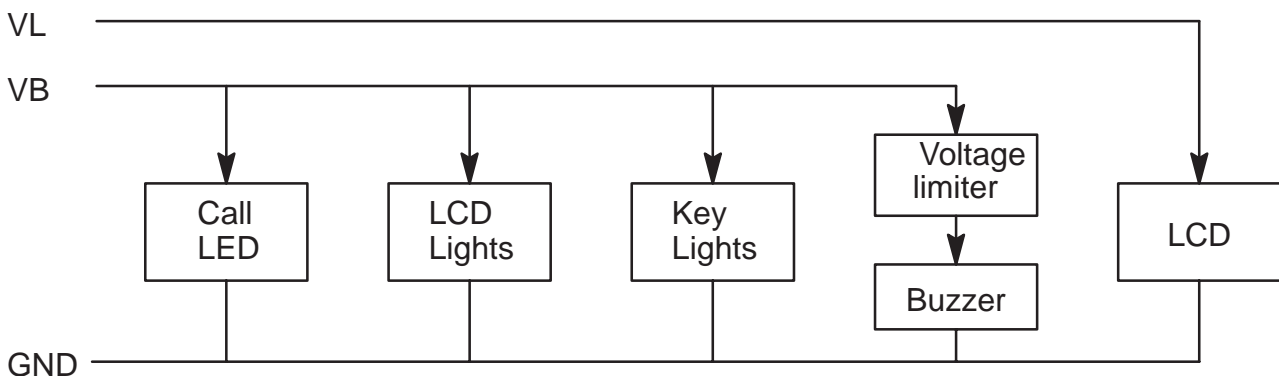

Led Drivers

The keyboard illumination is achieved by using two transistors (BCX19) wired as simple constant current sinks. Both transistors supply six LED's, so the keyboard is illuminated with 12 LED's. The bases of the two transistor are wired together and controlled by MCU via PSCLD. The led current is fixed by the values of R401 and R402 and the ratio of R411 to R413.

The display illumination operates in a similar way to the keyboard drivers, but only one transistors (V402) is used to drive six leds. The current in this case is defined by the value of R414 and the ratio of R412 to R404.

Call Indicator

The Call LED is fed from a simple emitter follower (V400). The led current is fixed by the value of R400.

Buzzer Driver

The buzzer is driven from NPN transistors (V403 and V425), which act as a buffer for a CMOS output signal applied at BUZZER.

The ringing volume is controlled by pulse width modulation.

The diode V413 prevents damage to the transistors when they switch off, absorbing the stored energy in the buzzer inductance and suppressing large positive going spikes on the transistor collectors.

Audio Circuitry

The microphone is routed through RF-suppression to UIF-connector X400 (pins 1 and 2)

The earpiece is routed directly to UIF- connector X400 (pins 17 and 18).

RF Suppression

Small value ceramic capacitors are fitted to audio lines to avoid problems with rf interference. In microphone lines, C406, C407, C412, C413, L1 and L2 trap common mode noise. Capacitors C410 and C411 have been placed near the earpiece pads.

Keyboard Scanning and Display Driver Control

COL(0-3) are used as column lines on keyboard. UIF(0-5) are used as row lines. UIF5 is also multiplexed with the display driver control signal.

When a key is pressed, the system ASIC gets an interrupt from a row and the MCU starts scanning. One column at a time is written to LOW and rows are used to read which key it was.

LCD Module

The LCD module includes the LCD and the display driver. The driver TAB has been connected to the LCD. The display driver type is SED1560 from SEIKO EPSON. It has an internal clock oscillator and a negative voltage generator to generate a negative rail required for operation. The oscillator frequency is fixed by the resistance from pins 16 to 17 of LCD- connector X401, with the value of R415, the frequency should be about 18kHz

The display driver is connected to the system board with a serial data bus. Data input is enabled when CS1 is LOW. A0 is control/display data flag input. Incoming data is control data when A0 is LOW, and display data when A0 is HIGH. Serial data is read on the rising edge of SCL. On every eight clock pulse, the data is transferred from the shift register and processed as 8-bit parallel data. A0 is read on the rising edge of every eight clock signal.

Circuit Diagram of GU8

Layout Diagram of GU8

Parts List of GU8 (EDMS issue: 1.9)

Code: 0200558

ITEM	CODE	DESCRIPTION	VALUE	TYPE
R400	1430009	Chip resistor	220	5 % 0.063 W 0603
R422	1430035	Chip resistor	1.0 k	5 % 0.063 W 0603
R404	1430043	Chip resistor	2.2 k	5 % 0.063 W 0603
R411	1430043	Chip resistor	2.2 k	5 % 0.063 W 0603
R412	1430043	Chip resistor	2.2 k	5 % 0.063 W 0603
R405	1430043	Chip resistor	2.2 k	5 % 0.063 W 0603
R413	1430047	Chip resistor	3.3 k	5 % 0.063 W 0603
R406	1430047	Chip resistor	3.3 k	5 % 0.063 W 0603
R421	1430051	Chip resistor	4.7 k	5 % 0.063 W 0603
R408	1430065	Chip resistor	10 k	5 % 0.063 W 0603
R420	1430071	Chip resistor	22 k	5 % 0.063 W 0603
R409	1430087	Chip resistor	100 k	5 % 0.063 W 0603
R407	1430087	Chip resistor	100 k	5 % 0.063 W 0603
R410	1430087	Chip resistor	100 k	5 % 0.063 W 0603
R415	1430111	Chip resistor	1.0 M	5 % 0.063 W 0603
R419	1430113	Chip resistor	348 k	1 % 0.063 W 0603
R401	1430163	Chip resistor	33	5 % 0.063 W 0603
R402	1430163	Chip resistor	33	5 % 0.063 W 0603
R414	1430163	Chip resistor	33	5 % 0.063 W 0603
R416	1430199	Chip resistor	432 k	1 % 0.063 W 0603
R403	1825001	Chip varistor vwm18v vc40v	0603	0603
C400	2310408	Ceramic cap.		Y5 V 1206
C401	2310408	Ceramic cap.		Y5 V 1206
C402	2310408	Ceramic cap.		Y5 V 1206
C403	2310408	Ceramic cap.		Y5 V 1206
C404	2310408	Ceramic cap.		Y5 V 1206
C431	2312293	Ceramic cap.		Y5 V 1206
C430	2312410	Ceramic cap.	1.0 u	10 % 16 V 1206
C409	2312410	Ceramic cap.	1.0 u	10 % 16 V 1206
C420	2312410	Ceramic cap.	1.0 u	10 % 16 V 1206
C421	2312410	Ceramic cap.	1.0 u	10 % 16 V 1206
C412	2320027	Ceramic cap.	4.7 p	0.25 % 50 V 0603
C413	2320027	Ceramic cap.	4.7 p	0.25 % 50 V 0603
C406	2320043	Ceramic cap.	22 p	5 % 50 V 0603
C407	2320043	Ceramic cap.	22 p	5 % 50 V 0603
C410	2320043	Ceramic cap.	22 p	5 % 50 V 0603
C411	2320043	Ceramic cap.	22 p	5 % 50 V 0603
C415	2320043	Ceramic cap.	22 p	5 % 50 V 0603
C405	2320110	Ceramic cap.	10 n	10 % 50 V 0603
C408	2320110	Ceramic cap.	10 n	10 % 50 V 0603
L001	3640011	Filt z>600r/100m Or6max 0.2a	0805	0805
L002	3640011	Filt z>600r/100m Or6max 0.2a	0805	0805
V413	4110070	Diode	BAS16W	75 V 0.25 A SOT323

UIF Module		Technical Documentation		
V418	4110070	Diode	BAS16W	75 V 0.25 A SOT323
V415	4110070	Diode	BAS16W	75 V 0.25 A SOT323
V430	4110072	Diode x 2	BAV99W	70 V 0.2 A SOT323
V400	4200836	Transistor	BCX19	npn 50 V 0.5 A SOT23
V402	4200836	Transistor	BCX19	npn 50 V 0.5 A SOT23
V404	4200836	Transistor	BCX19	npn 50 V 0.5 A SOT23
V405	4200836	Transistor	BCX19	npn 50 V 0.5 A SOT23
V403	4200836	Transistor	BCX19	npn 50 V 0.5 A SOT23
V425	4200836	Transistor	BCX19	npn 50 V 0.5 A SOT23
V432	4210100	Transistor	BC848W	npn 30 V SOT323
N401	4340065	Mic5201 regld 5v 0.2a 1%	sot223	SOT223
H400	4850073	IC, lcd+driver graphic do DSL/HD843		DOTM
V401	4860005	Led	Green	0603
V411	4860005	Led	Green	0603
V412	4860005	Led	Green	0603
V419	4860005	Led	Green	0603
V420	4860005	Led	Green	0603
V429	4860005	Led	Green	0603
V406	4864389	Led		0603
V408	4864389	Led		0603
V409	4864389	Led		0603
V410	4864389	Led		0603
V414	4864389	Led		0603
V416	4864389	Led		0603
V417	4864389	Led		0603
V421	4864389	Led		0603
V422	4864389	Led		0603
V423	4864389	Led		0603
V424	4864389	Led		0603
V427	4864389	Led		0603
V428	4864389	Led		0603
B400	5140029	SM, d buzzer 94db 5vdc40r 14x11		14x11x3
X400	5469288	SM, conn 2x15 f p0.8 pcb/pcb 2.8		2.8MM
	9460168	Reflector dmc00050 nhe-6		
	9460217	Buzzer gasket dmd02853 nhe-6 gu		GU8
	9790163	Volyme keypad dmd000097		
	9790164	Power keypad dmc00009 nhe-6		
	9795018	Keydomes		4C25593 NHE-6
	9795019	Keydomes		4C25596 NHE-6
	9855024	PCB FLEX GU8 202.5X135.9 D 3/PA		
	9855024	PC board	FLEX	gu8 202.5x135.9 d 3/pa